

# Hydrological Equipment for Community Early Warning

- Volunteers for the promotion of Community Early Warning :VCEW-

The early warning equipment is composed of MONITOR/WARNING UNIT, RAIN GAUGE and STREAM GAUGE. The monitor/warning unit is set up in the observer's house. The rain gauge and the stream gauge are installed at the observation sites and are connected to the monitor/warning unit by a cable.

These equipment can be assembled locally with parts available universally except for the relay. (Photo shows staff of Ministry of Irrigation, Nepal assembling the equipment)



When the accumulated rainfall or water level reaches the pre-set levels the lamps flash and the buzzer sounds. With this automatic warning function, the equipment is useful particularly for early warning of flash-floods and debris-flows by heavy rains concentrated over a small catchment for a short period.

The pre-set levels may be for alert, for evacuation of the weak, for evacuation of all community people etc. Equipment with the sensor of five levels is shown below for example.

The approximate cost is as follows: 50 US\$ for MONITOR/WARNING UNIT, 20 US\$ for RAIN GAUGE, 40 US\$ for STREAM GAUGE and 1.2 US\$ per one meter for the connecting cable. (as of April 2011, Tokyo)

## MONITOR/WARNING UNIT

The monitor/warning unit is designed to apply to both the rainfall and water level. AC converter, battery and/or solar system may supply the 12 volts power.

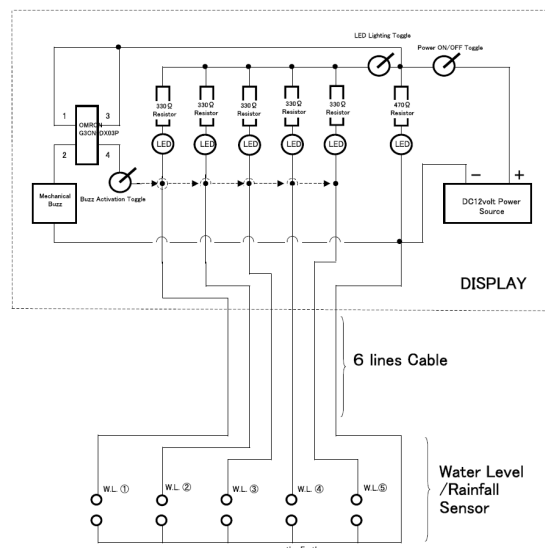
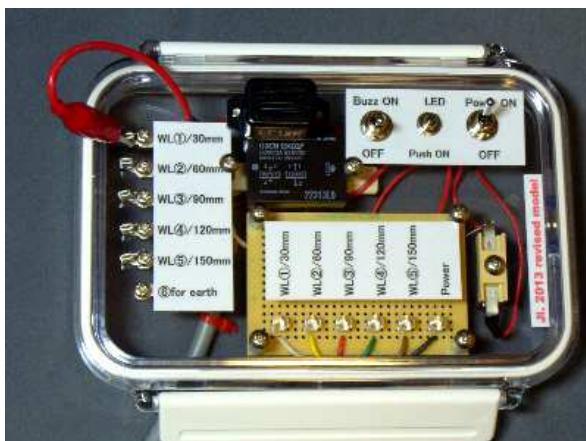

## RAIN GAUGE

The rain gauge is composed of a rain accumulating part and a sensor stick hooked on the side of the accumulating part. The gauge is usually installed near-by the observer's house.

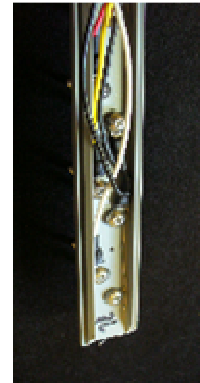
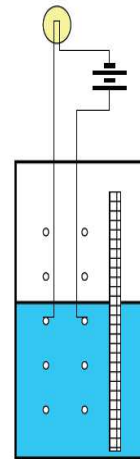

## STREAM GAUGE

The stream gauge is composed of a casing pipe and a sensor rod. The stainless steel terminals for sensing are placed on the sensor rod. The photo on the right shows a stream gauge attached to gabion revetment of river bank, with the bottom elevated from the river bed.

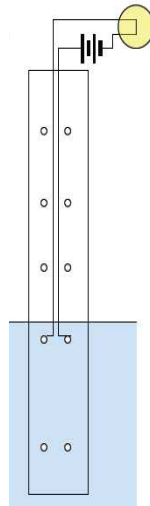
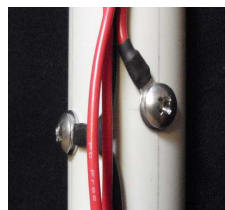

For further information please contact:

Mr. Hidetomi Oi

Volunteers for the promotion of Community Early Warning (VCEW)

Email : [h-oi@waltz.plala.or.jp](mailto:h-oi@waltz.plala.or.jp)